

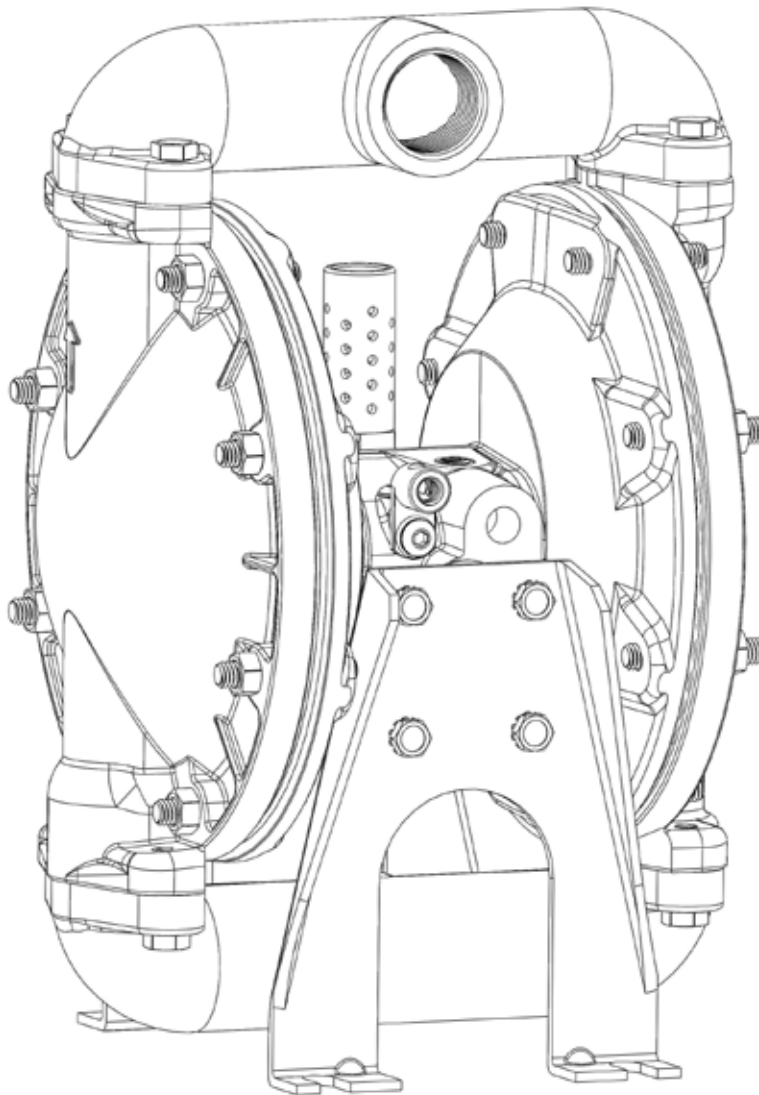

PUMP-FIT MODEL SERIES PF6661

Assembly, Installation and Operation Manual





EU Declaration of Conformity



Pump-Fit hereby declares that the following machine(s) fully comply with the applicable health and safety requirements as specified by the EC Directives listed. The complete product complies with the provisions of the EC Directive on machinery safety.

This declaration is valid provided that the devices are fully assembled and no modifications are made to these devices.

Type of Device:

Air Operated Double Diaphragm Pumps

Models:

PF666100-3EB-C PF666100-344-C
PF666120-3EB-C PF666120-344-C

EC Directives:

Machinery Safety (2006/42/EC)

Applied Harmonized Standards:

EN ISO 12100 Part 1
EN ISO 12100 Part 2

Manufacturer:

Pump-Fit
921 Greengarden Road
Erie, Pennsylvania 16501-1591 U.S.A

Signed,

President

10 April 2015

Person(s) Authorized to Compile Technical File: Pump-Fit GmbH
Otto-Hahn-Strasse 16
Maintal, D-63477 DEU
Telephone: 49 (0)6181-90878-0

EC Declaration of Conformity ATEX 100A

Manufactured by:

Finish Thompson, Inc.
921 Greengarden Road
Erie, Pennsylvania 16501 U.S.A.
Phone: 1-(814)-455-4478
Fax 1-(814)-455-8518
Email: fti@finishthompson.com
Web: www.finishthompson.com



II 2 GD c IIB TX
FTZU 15 ATEX A437-15

This declaration applies to Finish Thompson PF6661 Series pumps. Model Numbers PF6661XX-XXX-C.

Finish Thompson declares under our sole responsibility that the product listed below conforms to the relevant provisions of EC directive 94/9/EC of 23 March 1994 for equipment and protective systems intended for use in potentially explosive atmospheres, and is certified for safe use in Group 2 category 2 areas.

This product has used the following harmonized standards to verify conformance:

Non-electrical equipment for potentially explosive atmospheres: EN13463-1: 2009
Basic Methods and Requirements.

Non-electrical equipment intended for use in potentially explosive atmospheres: EN13463-5:2011
Protection by construction safety "c."

This product must not be used in areas other than specified above. If in doubt consult an authorized distributor, or refer to the manufacturer Finish Thompson.

Approved by:

Date: 10/06/2015

Table of Contents

Important Information - Read Me First	
Chemical Reaction Disclaimer.....	5
Safety Precautions	5
Part Number Explanation.....	6
Pump Data.....	6
Installation & Operation Precautions	7
Section I - Maintenance	7
Section II - Disassembly / Reassembly Fluid Section.....	7-8
Section III - Disassembly/Reassembly Pilot Valve	8
Section IV - Disassembly/Reassembly Major Valve.....	9
Section V - Troubleshooting	9-10
Section VI - Warranty.....	10
Spare Parts Diagram	11
Spare Parts List.....	12-13
Dimensional Drawing	14

Pump-Fit Contacts:

Headquarters (USA)

Tech Service: PH: 800-888-3743;

Email: techservice@finishthompson.com

Order Fax: 814-459-3460 or 814-455-8518

Sales: 1-814-455-4478; Toll Free 1-800-934-9384 (U.S. & Canada)

Europe Center (Germany)

Tech Service: PH: +49 (0)6181-90878-0

Email: europcenter@finishthompson.com

Order Fax: +49 (0)6181-90878-18

Sales: +49 (0)6181-90878-0

IMPORTANT INFORMATION-READ ME FIRST!

Model Number and Serial Number

Record the model number and serial number below for future reference. This is important information when ordering replacement parts or when technical assistance is required. The numbers are found on a label located on the pump body next to the air valve.

MODEL NUMBER = _____

SERIAL NUMBER = _____

Chemical Reaction Disclaimer

The user must exercise primary responsibility in selecting the product's materials of construction, which are compatible with the fluid(s) that come(s) in contact with the product. The user may consult Pump-Fit (manufacturer) and a manufacturer's representative/distributor agent to seek a recommendation of the product's material of construction that offers the optimum available chemical compatibility.

However neither manufacturer nor agent shall be liable for product damage or failure, injuries, or any other damage or loss arising out of a reaction, interaction or any chemical effect that occurs between the materials of the product's construction and fluids that come into contact with the product's components .

Safety Precautions

⚠ WARNING: READ THIS MANUAL COMPLETELY BEFORE INSTALLING AND OPERATING THIS PUMP. FAILURE TO FOLLOW THESE PRECAUTIONS CAN RESULT IN SERIOUS INJURY OR DEATH.

⚠ WARNING Do not exceed maximum pressure stated on the pump serial number sticker. Pump exhaust may be loud and contain particles. Wear appropriate ear and eye protection. In the event of a diaphragm rupture material can be forced out of the air exhaust muffler. If product is hazardous or toxic pipe exhaust to appropriate safe area.

⚠ WARNING: Chemical Hazard. This pump is used for transferring many types of potentially dangerous chemicals. Always wear protective clothing, eye protection and follow standard safety procedures when handling corrosive or personally harmful materials. Proper procedures should be followed for draining and decontaminating the pump before disassembly and inspection of the pump. There may be small quantities of chemicals present during inspection.

⚠ WARNING Before maintenance or repair, close the compressed air supply valve, bleed the pressure and disconnect air line from the pump. Discharge line may be pressurized. Any pressure must be relieved before service.

⚠ WARNING Static sparking can cause explosion. When operating in a hazardous area or pumping a hazardous fluid, the pump's grounding screw and entire pump system must be grounded to earth to prevent static discharge. This includes but is not limited to pipes, hoses, tanks, containers, valves, etc. Before operating the pump, ensure the electrical continuity throughout the pumping system and earth ground is 1 Ohm or less. If it is greater than one 1 Ohm, re- check all grounding connections.

⚠ WARNING Static sparking can cause explosion. Excessive fluid flowrates and improper tank filling methods can produce static electricity. Ensure safe fluid velocities and tank filling procedures in compliance with EN 13463-1 and CLC/TR 50404.

⚠ WARNING Vibrations from operation may cause mounting surfaces and connections to loosen and generate a spark. Ensure the pump and connections are securely mounted and fastened prior to each operation.

⚠ WARNING: Do not exceed minimum and maximum temperature limits of pump components. A table of temperature limits is provided in the "Pump Data" section of this manual.

⚠ WARNING: Prior to operating, check pump for any worn o-rings, gaskets, or seals. Any leaking or damaged o-rings, gaskets, or seals must be repaired or replaced immediately.

⚠ WARNING: Pump must be cleaned on a regular basis to avoid dust buildup greater than 5mm.

⚠ WARNING: The surface temperature of the pump depends upon the temperature of the fluid that is being pumped. The chart below lists different fluid temperatures and the corresponding pump surface temperatures, which determine the Temperature Class when operating in a hazardous area or pumping a hazardous fluid.

Fluid Temperature	Maximum Surface Temperature	Temperature Class	Maximum Allowable Surface Temperature
145° F (63° C)	145° F (63° C)	T6	85° C
203° F (95° C)	203° F (95° C)	T5	100° C
266° F (130° C)	266° F (130° C)	T4	135° C
356° F (180° C)	356° F (180° C)	T3	200° C

CAUTION Do not use the pump as the support for the piping system. System components must be properly supported to prevent stress on the pump parts.

Suction and discharge connections should be flexible connections (such as hose), not rigid piped, and must be compatible with the substance being pumped and system pressure.

CAUTION To help avoid unnecessary damage to the pump, do not allow pump to run dry for long periods of time.

CAUTION Use only genuine Pump-Fit replacement parts to assure compatible pressure rating and longest service life.

CAUTION If pump is used with materials that tend to solidify or settle pump should be flushed after each use to prevent damage.

NOTICE Install the pump in a vertical position or the pump may not prime properly.

NOTICE Re-torque all fasteners and inspect pump for leaks before operation. Creep of housing and gasket materials may cause fasteners to loosen. Re-torque all fasteners to insure against fluid or air leakage.

NOTICE Unpack the pump and examine for any signs of shipping damage. If damage is detected, save the packaging and notify the carrier immediately.

Part Number Explanation

Part Number Model Codes						
PF666100-3EB-C, PF666100-344-C, PF666120-3EB-C, & PF666120-344-C						
Model	(Air) Motor Body	Fluid Cap & Manifold	Seat Material	Ball Material	Diaphragm Material	
PF6661	0	0	3	E	B	C
PF6661	0	0	3	4	4	C
PF6661	2	0	3	E	B	C
PF6661	2	0	3	4	4	C
	(0-Aluminum/FNPT)	(0-Aluminum)	(3-Polypropylene)	(E-Santoprene)	(B-Santoprene)	
	(2-Aluminum/FBSP)			(4-PTFE)	(4-PTFE/Santoprene)	

Pump Data

Pump Type: Aluminum Air Operated Double Diaphragm	
Weight: 19.4 lbs / 8.8 kgs	Max Flow Rate: 35 GPM (133 lpm)
Air Inlet Size: 1/4" FNPT	Suction/Discharge Size: 1" FNPT or 1" FBSP
Max Air Inlet Pressure: 120 psig (8.3 bar)	Max Particle Size: 1/8" (3.2 mm)
Max Material Inlet Pressure: 10 psig (.69 bar)	Max outlet Pressure: 120 psig (8.3 bar)
Displacement Per Stroke: Santoprene = 0.16 gal. (0.60 lit.), PTFE = 0.14 gal. (0.525 lit.)	
Maximum Temperature Limits for Elastomers, Balls Seats & Diaphragms:	
Polypropylene: 35° to 175° F (2° to 79° C)	
Santoprene: -40° to 225° F (-40° to 107° C)	
PTFE: 40° to 225° F (4° to 107° C)	
Maximum Noise Level: 71 dB (A)	

Installation / Operation Precautions

Installation

Pump should be located as close to the fluid supply as possible. Keep the suction line length short & fittings to a minimum. Use a minimum of 1" suction line diameter. When using rigid pipe run short sections of flexible hose between the pump & piping. Secure the pump base to a suitable surface.

Operation

The Pump-Fit PF6661 Models diaphragm pumps are a 1:1 ratio design and will provide up to 35 GPM (133 lpm) of flow and up to 100 psi of discharge pressure.

Ball checks ensure a positive flow of fluid. Pump will start cycling as air pressure is applied. Pump will build and maintain line pressure and will stop cycling once maximum line pressure is reached or discharge is closed. Pump will resume pumping when line pressure drops or discharge valve is reopened.

If pumping materials that are subject to crystallizing, always flush the pump with a non-flammable fluid compatible with the pump's materials of construction.

The flow rate is controlled not only by the air supply but also by the fluid being pumped. Fluid viscosity will reduce the obtainable flow rate. Use a minimum of a 1" discharge line diameter to reduce friction losses. Be sure to use vacuum rated hose on the suction side.

Section I – Maintenance

Inspect and replace worn parts with new parts as necessary. Look for damage on metallic surfaces, nicks or cuts on seals & o-rings. Recommended tools: 7/16" wrench, 1/2" wrench, 7/16" socket, 1/2" socket, torque wrench, o-ring pick, 3/8" allen wrench & snap ring pliers.

Section II – Disassembly / Reassembly Fluid Section

FLUID SECTION DISASSEMBLY

1. Remove 4 discharge manifold bolts (item 14) and lift the discharge manifold (top) (item 10) off of the motor body (item 17).
2. Remove the balls (item 13), o-rings (item 11) and seats (item 12) from the fluid cap (item 9).
3. Invert the pump and set it on the discharge fluid cap flanges (item 9). Remove the 4 suction manifold bolts (item 14) and suction manifold (item 10).
4. Remove the balls (item 13), o-rings (item 11), and seats (item 12) from the fluid caps (item 9).
5. Stand the motor body (item 17) on the pump legs (item 22) and remove the 8 nuts (item 15) from both fluid caps (item 9). Pull the fluid cap (item 9) away from the motor body (17). Note: If balls (item 13), o-rings (item 11) and seats (item 12) were not removed in step 2 or 4 they can be removed now by accessing them from the inside of the fluid caps (item 9).
6. Remove diaphragm bolt (item 8), diaphragm washer (item 7), o-rings (item 3), diaphragm plates (items 4 & 5), diaphragms (item 6 or 6A & 6B) from diaphragm connecting rod (item 1).
7. Remove connecting rod (item 1) from air motor (item 17) by pulling on the remaining diaphragm. Rod should pull out easily from the motor body.
8. Carefully remove remaining diaphragm bolt (item 8), diaphragm washer (item 7), o-rings (item 3), diaphragm plates (items 4 & 5), diaphragms (item 6 or 6A & 6B) from diaphragm connecting rod (item 1). Be careful not to damage the surface of the connecting rod.
9. Remove o-ring (item 2) from connecting rod (item 1)

FLUID SECTION REASSEMBLY

1. Position the motor body on the pump legs. Lubricate connecting rod (item 1) and o-ring (item 2) with white lithium grease or equivalent o-ring lubricant and push into motor body (item 17).
2. Reinstall diaphragm plates (items 4 & 5) with chamfer toward diaphragms, diaphragms (item 6 or 6A & 6B), o-rings (item 3) and diaphragm washer (item 7) onto the diaphragm bolt (item 8). Refer to diaphragm figure below for proper placement. Note: install the santoprene backer diaphragm with the side labeled “Air Side” toward the motor body (item 17) & the PTFE diaphragm with the side labeled “Air Side” toward the fluid cap (item 9). Make sure holes in the diaphragms align with the studs (item 39) from the motor body (item 17). Once both sides are installed onto the connecting rod (item 1) tighten the diaphragm bolt on one side while holding the other bolt with a wrench. Tighten to: 25 - 30 ft. lbs (33.9 – 40.7 Nm).
3. Reinstall Fluid caps (item 9) onto motor body (item 17) with nuts (item 15) alternately and evenly, and tighten to: 120 - 140 in. lbs (13.6 - 15.8 Nm) then re-torque after initial run-in.
4. Reinstall seats (item 12), o-rings (item 11) & balls (item 13). Make sure the o-rings are seated properly.
5. Invert the pump and set it on the discharge fluid cap flanges (item 9). Reinstall suction manifold (item 10) & 4 - bolts (item 14) tighten alternately and evenly, torque to: 120-140 in. lbs (13.6-15.8 Nm) then re-torque after initial run-in.
6. Invert the pump and stand the motor body (item 17) on the pump legs (item 22). Reinstall discharge manifold (item 10) & 4 - bolts (item 14) tighten alternately and evenly, and torque to: 120-140 in. lbs (13.6-15.8 Nm) then re-torque after initial run-in.

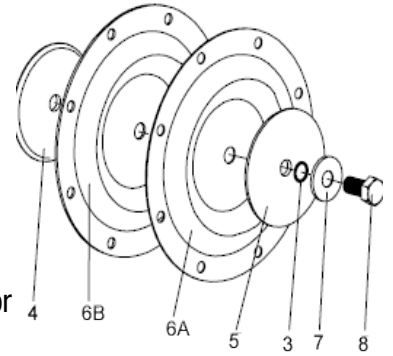

Section III – Disassembly / Reassembly – Pilot Valve

PILOT VALVE DISASSEMBLY

1. Remove snap rings, screws, o-rings & sleeve bushings (items 20, 38, 37 & 36). Press the pilot rod (item 33) out of the motor body (item 17) using a wood or plastic dowel. Pull out remaining o-rings & spacers (items 34 & 35).
2. Remove diaphragm connecting rod sleeve & o-rings (items 19 & 18).

PILOT VALVE REASSEMBLY

1. Reinstall sleeve (item 19) and new o-rings (item 18) into the diaphragm connecting rod bore in the motor body (item 17). Lubricate all o-rings with white lithium grease or equivalent o-ring lubricant.
2. Install one of the sleeve bushings & screws (item 36 & 38) into the pilot valve bore and tighten. Apply Loctite 262 to the screw threads. Insert new o-rings & spacers (items 34 & 35) into the pilot valve bore. Important: These items must be installed in the proper order for the pilot valve to work properly. Refer to the exploded view below for correct sequence. Lubricate all o-rings with white lithium grease or equivalent o-ring lubricant.

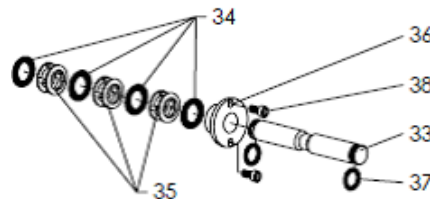

3. Insert the pilot rod carefully into the pilot valve bore. Push it through the o-rings & spacers (items 34 & 35) until the end protrudes out of the sleeve bushing (item 36) previously installed. Install a new o-ring (item 37) in the o-ring groove on the end of the shaft to hold it in place. Reinstall the other sleeve bushing & screws (items 36 & 38) over the other end

of the pilot rod & tighten the screws. Apply Loctite 262 to the screw threads. Install a new o-ring (item 37) on the end of the pilot rod.

4. Reinstall the diaphragm connecting rod sleeve (item 19) snap rings (item 20).

Section IV – Disassembly / Reassembly – Major Valve

MAJOR VALVE DISASSEMBLY

1. To disassemble the major valve first remove the pump foot screws, pump feet & gaskets (items 21, 22, 23 & 32).
2. Use a wood or plastic dowel to push the spool (item 26) toward the piston (item 24). Push from the muffler side of the pump toward the air inlet side. This will remove the piston, u-cup and spool (items 24, 25 & 26) from the motor body (item 17). Note: Make sure not to damage the surface of the spool (item 26).
3. Pull out the remaining washers, o-rings & spacers left in the pilot valve bore (items 27, 28, 29, 30 & 31).

MAJOR VALVE REASSEMBLY

1. Prior to reinstalling the spool (item 26) it is recommended to replace the 5 washers (item 27) & 11 o-rings (items 28 & 29).
2. Preassemble the washers, o-rings & spacers (items 27, 28, 29, 30 & 31) onto the spool (item 26). Lubricate the spool with white lithium grease or equivalent o-ring lubricant prior to assembly. See the following figure for correct orientation.

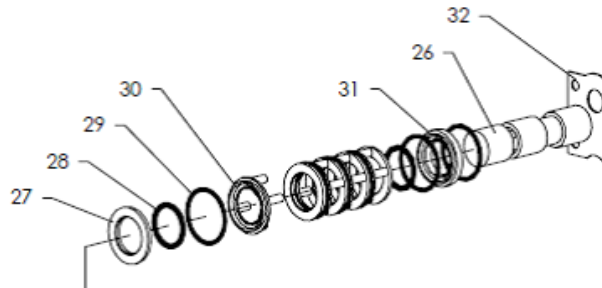

3. Lubricate the OD of the washers, o-rings & spacers (items 27, 28, 29, 30 & 31) with white lithium grease or equivalent o-ring lubricant after assembly.
4. Reinsert the spool assembly into the motor body (item 17) on the muffler side of the pump and push it in towards the air inlet side. Replace the u cup (item 25) on the piston (item 24) and press it into the motor body (item 17) on the air inlet side.
5. Replace gaskets (items 23 & 32) with new gaskets. Reinstall the pump feet, screws & gaskets (item 22, 21, 23 & 32). Gasket (item 23) has a notch at the top & is installed on the piston or air inlet side. Gasket (item 32) is installed on the muffler side. Tighten pump foot screws (item 21) to: 40-50 in. lbs. (4.5 - 5.6 Nm).

Section V - Troubleshooting

If pumped material is coming out of the pump's air exhaust.

- Check for ruptured diaphragms (item 6, 6A, & 6B).
- Check proper torque of diaphragm screws (item 8).

If air bubbles are present in the Pumps discharge line.

- Check all suction plumbing connections.
- Check all o-rings from the intake manifolds (item 11) to the fluid caps (item 9).
- Check proper torque of diaphragm screws (item 8).

If low flow.

- Check air pressure & cfm.
- Check for restrictions in the suction or discharge hose / piping.
- Is the pump priming properly? Make sure pump is mounted in the vertical position.
- Is the pump cavitating? Suction pipe should be 1" minimum or larger.
- Suction hose must be vacuum rated.
- Check all o-rings from the intake manifolds (item 11) to the fluid caps (item 9).
- Check to make sure balls (item 3) are seating properly with seats (item 12).
- If cycling or erratic performance occurs replace o-rings (items 34 & 37) on pilot rod (item 33).

If Pump Stalls and air blows air out exhaust.

- Check o-rings (items 28, & 29) on pilot rod (item 26) for wear or damage and replace.

Phone Pump-Fit's Technical Service Department at 1-800-888-3743 or e-mail techservice@finishthompson.com if you have any questions regarding product operation or repair.

Section VI - Warranty

Pump-Fit (manufacturer) warrants this pump product to be free of defects in materials and workmanship for a period of two years from date of purchase by original purchaser. If a warranted defect, which is determined by manufacturer's inspection, occurs within this period, it will be repaired or replaced at the manufacturer's option, provided (1) the product is submitted with proof of purchase date and (2) transportation charges are prepaid to the manufacturer. Liability under this warranty is expressly limited to repairing or replacing the product or parts thereof and is in lieu of any other warranties, either expressed or implied. This warranty does not apply to normal wear of the product or components. This warranty does not apply to products or parts broken due to, in whole or in part, accident, overload, abuse, chemical attack, tampering, or alteration. The warranty does not apply to any other equipment used or purchased in combination with this product. The manufacturer accepts no responsibility for product damage or personal injuries sustained when the product is modified in any way. If this warranty does not apply, the purchaser shall bear all cost for labor, material and transportation.

Manufacturer shall not be liable for incidental or consequential damages including, but not limited to, process down time, transportation costs, costs associated with replacement or substitution products, labor costs, product installation or removal costs, or loss of profit. In any and all events, manufacturer's liability shall not exceed the purchase price of the product and/or accessories.

Ordering Spare Parts

Spare parts can be ordered from your local Pump-Fit distributor. For a list of Pump-Fit distributors go to <http://www.pumpfit.net/>.

Always refer to the pump model to avoid ordering incorrect parts.

Other PUMP-FIT Products

See our full product range at <http://www.pumpfit.net/>.

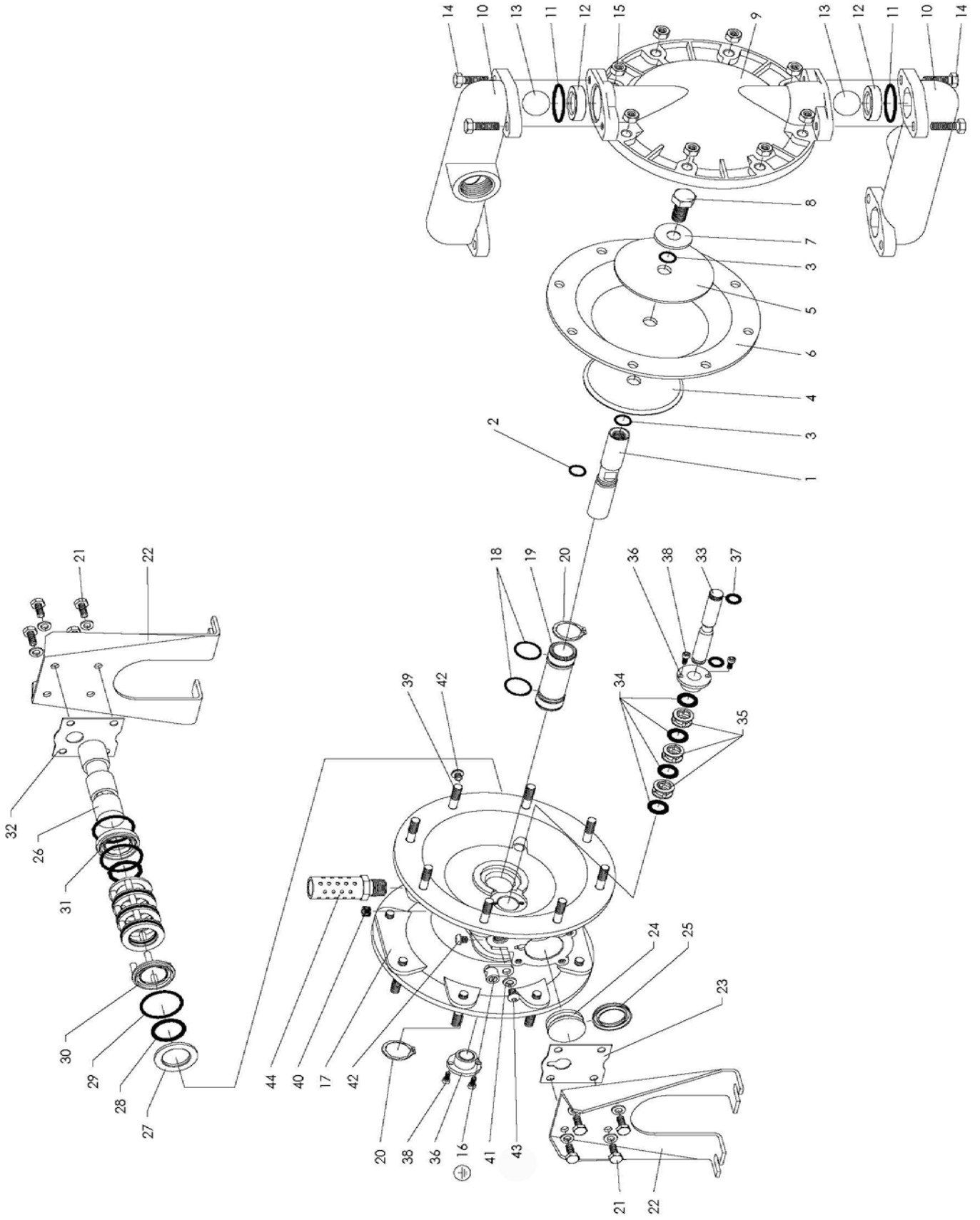

PF6661 Model Spare Parts

Item	Description	Qty	Part Number	Material Code
1	Diaphragm Connecting Rod	1	PF98724-1	[C]
2	O-Ring (3/32" x 3/4" OD)	1	PFY330-113	[B]
3	O-Ring (1/16" x 5/8" OD)	4	PFY328-14	[T]
4	Washer-Air Side (3-5/8" OD)	2	PF93441-2	[C]
5	Washer-Fluid Side	2	PF93441-1	[SS]
6	Diaphragm	2	PF90533-B	[SP]
6A	Diaphragm (also requires 2 - PF92973-B Diaphragms)	2	PF93459-4	[T]
6B	Diaphragm (required for use with PF93459-4 above)	2	PF92973-B	[SP]
7	Washer (0.505" ID)	2	PF93189-1	[SS]
8	Screw (1/2"-20 x 1")	2	PFY5-85-T	[SS]
9	Fluid Cap	2	PF94945	[A]
10	Manifold	2	PF92001	[A]
11	O-ring (3/32" x 1-9/16" OD)	4	PF90534	[E]
11	O-ring (3/32" x 1-9/16" OD)	4	PFY328-126	[T]
12	Seat	4	PF92926	[P]
13	Ball	4	PF90532-A	[SP]
13	Ball	4	PF90532-4	[T]
14	Bolt (5/16"-18 x 1")	8	PFY6-55-C	[C]
15	Nut (5/16"-18)	16	PFY12-5-C	[C]
16	Ground Lug	1	PF93004	[Co]
17	Motor Body	1	PF94743	[A]
18	O-Ring (1/16" x 1" OD)	2	PFY325-20	[B]
19	Diaphragm Rod Sleeve	1	PF94527	[D]
20	Retaining Ring, Tru Arc (0.925" ID)	2	PFY145-25	[C]
21	Screw & Lock Washer (1/4"-20 x 5/8")	8	PF93860	[C]
22	Leg	2	PF92003	[C]
23	Gasket (with notch)	1	PF92878	[B/Ny]
24	Piston	1	PF92011	[D]
25	U-Cup (3/16" x 1-3/8" OD)	1	PFY186-51	[B]
26	Spool	1	PF92005	[A]
27	Washer (1.557" OD)	5	PF92877	[Z]
28	O-Ring (small)(1/8" x 1-1/4" OD)	5	PFY325-214	[B]
29	O-Ring (large)(3/32" x 1-9/16" OD)	6	PFY325-126	[B]
30	Spacer	4	PF92876	[Z]
31	Spacer	1	PF92006	[Z]
32	Gasket	1	PF92004	[B/Ny]
33	Pilot Rod	1	PF93309-1	[C]

Item	Description	Qty	Part Number	Material Code
34	O-Ring (1/8" x 3/4" OD)	4	PF93075	[U]
35	Spacer	3	PF115959	[Z]
36	Sleeve Bushing	2	PF98723-1	[Bz]
37	O-Ring (3/32" x 9/16" OD)	2	PF94820	[U]
38	Screw (#8-32 x 3/8")	4	PFY154-41	[C]
39	Stud (5/16"-18 x 1-3/4")	16	PF92866	[C]
40	Pipe Plug (1/8-27N.P.T. x 1/4")	1	PFY227-2-L	[C]
41	Lock Washer (1/4")	1	PFY14-416-T	[SS]
42	Button Head Screw (1/4"-20 x 1/4")	2	PF94987	[SS]
43	Button Head Screw (1/4"-20 x 3/8")	1	PF94987-1	[SS]
44	Muffler	1	PF93110	[C]
45	White Lithium Grease	1	110100	
	Service Kit-Santoprene - Includes items: 2, 3, 6, 11, 13 & 45	1	PF637119-EB-C	[Sp,E]
-	Service Kit-PTFE-Includes item: 2, 3, 6A, 6B, 11, 13 & 45	1	PF637119-44-C	[T,Sp]
-	Service Kit-Air Valve- Includes items: 18, 20, 23, 25, 28, 29, 32, 34, 37, 38 & 45	1	PF637118-C	[B,U,C,SY,CK]

Mat'l Codes: **SS**=Stainless Steel, **B**=Nitrile, **GFN**=Glass Filled Nylon, **P**=Polypropylene, **Sp**=Santoprene, **E**=E.P.R., **Bz**=Bronze, **C**=Carbon Steel, **D**=Acetal, **U**=Polyurethane, **Z**=Zinc, **SY**=Syn-Seal, **CK**=Ceramic.

OUTLINE DIMENSIONS

ALL DIMENSIONS ARE FOR REFERENCE ONLY

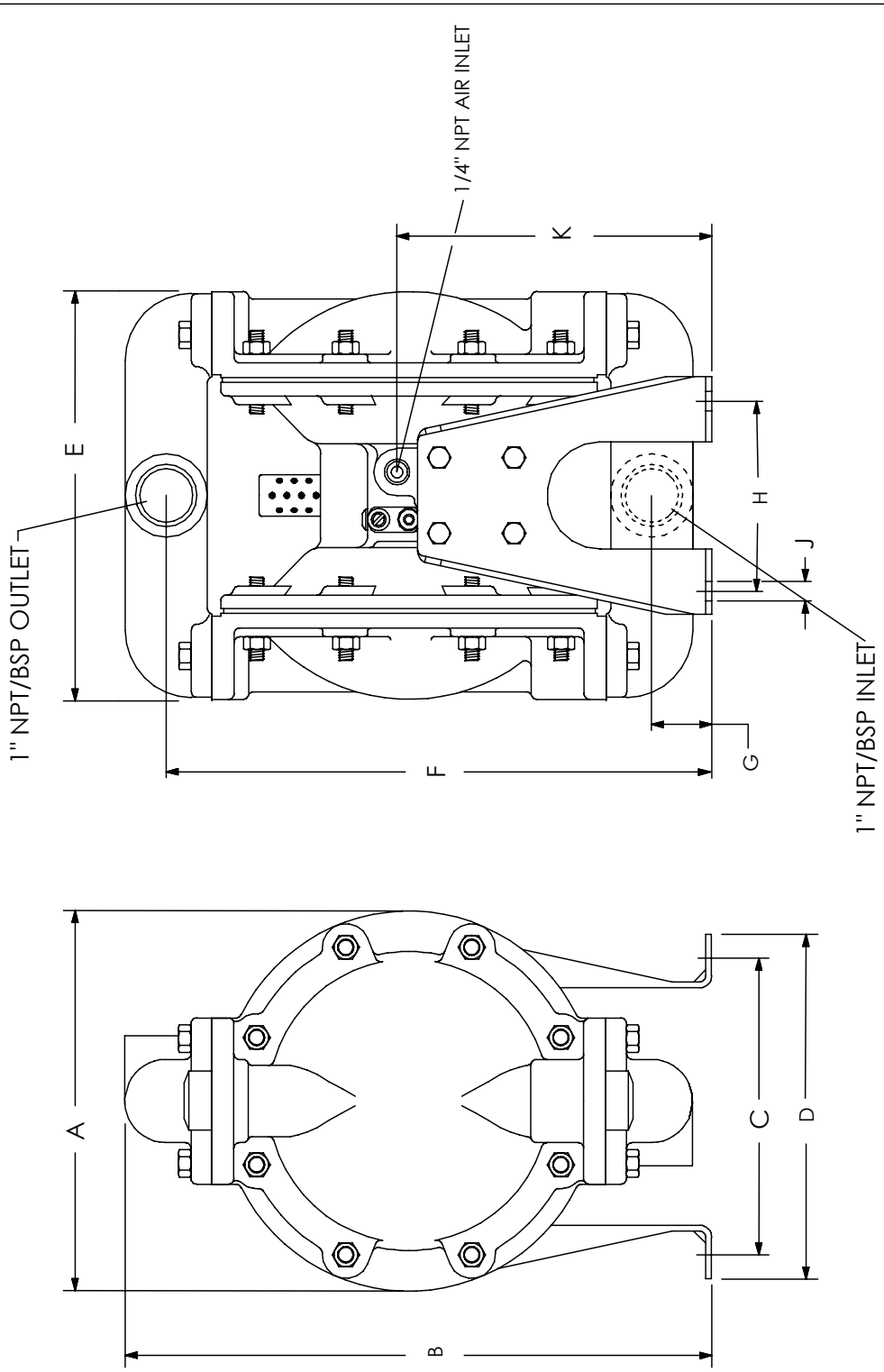

DIMENSIONS

A - 8.00" (203 mm)	E - 8.56" (218 mm)	J - 0.41" (10 mm)
B - 12.50" (318 mm)	F - 11.56" (294 mm)	K - 6.50" (165 mm)
C - 6.25" (159 mm)	G - 1.25" (32 mm)	
D - 7.31" (186 mm)	H - 4.00" (102 mm)	

